

Centre No.						Paper Reference						Surname	Initial(s)	
Candidate No.						<b>1</b>	<b>3</b>	<b>8</b>	<b>0</b>	<b>/</b>	<b>3</b>	<b>H</b>	Signature	

Paper Reference(s)

**1380/3H**

**Edexcel GCSE**

**Mathematics (Linear) – 1380**

**Paper 3 (Non-Calculator)**

**Higher Tier**

**Monday 6 June 2011 – Afternoon**

**Time: 1 hour 45 minutes**



Examiner's use only

--	--	--

Team Leader's use only

--	--	--

**Materials required for examination**

Ruler graduated in centimetres and millimetres, protractor, compasses, pen, HB pencil, eraser.  
Tracing paper may be used.

**Items included with question papers**

Nil

**Instructions to Candidates**

In the boxes above, write your centre number, candidate number, your surname, initials and signature.

Check that you have the correct question paper.

Answer ALL the questions. Write your answers in the spaces provided in this question paper.

**You must NOT write on the formulae page.**

**Anything you write on the formulae page will gain NO credit.**

If you need more space to complete your answer to any question, use additional answer sheets.

**Information for Candidates**

The marks for individual questions and the parts of questions are shown in round brackets: e.g. (2).

There are 27 questions in this question paper. The total mark for this paper is 100.

There are 28 pages in this question paper. Any blank pages are indicated.

**Calculators must not be used.**

**Advice to Candidates**

Show all stages in any calculations.

Work steadily through the paper. Do not spend too long on one question.

If you cannot answer a question, leave it and attempt the next one.

Return at the end to those you have left out.





## GCSE Mathematics (Linear) 1380

Formulae: Higher Tier

**You must not write on this formulae page.  
Anything you write on this formulae page will gain NO credit.**

**Volume of a prism** = area of cross section  $\times$  length

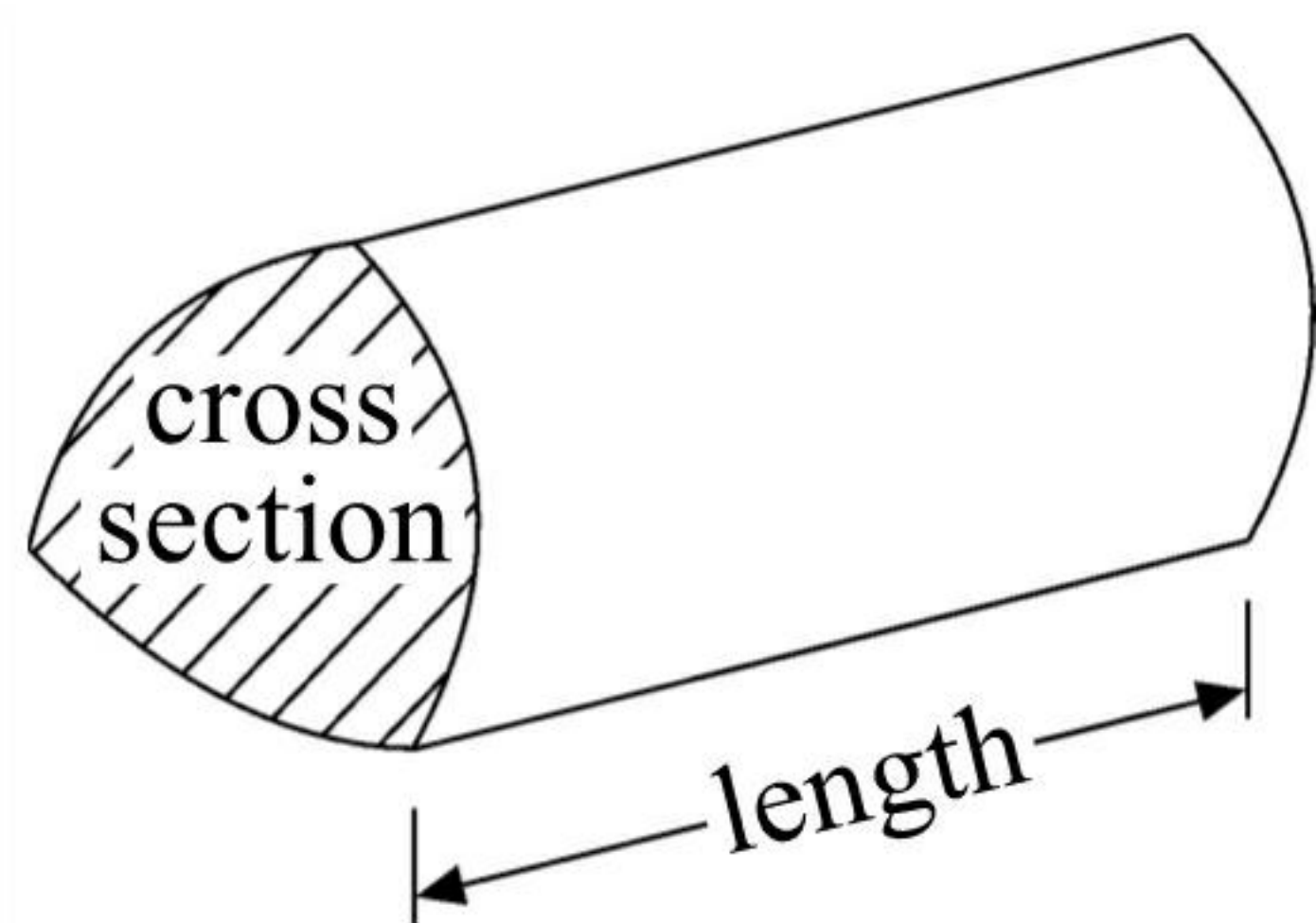

**Volume of sphere** =  $\frac{4}{3}\pi r^3$

**Surface area of sphere** =  $4\pi r^2$

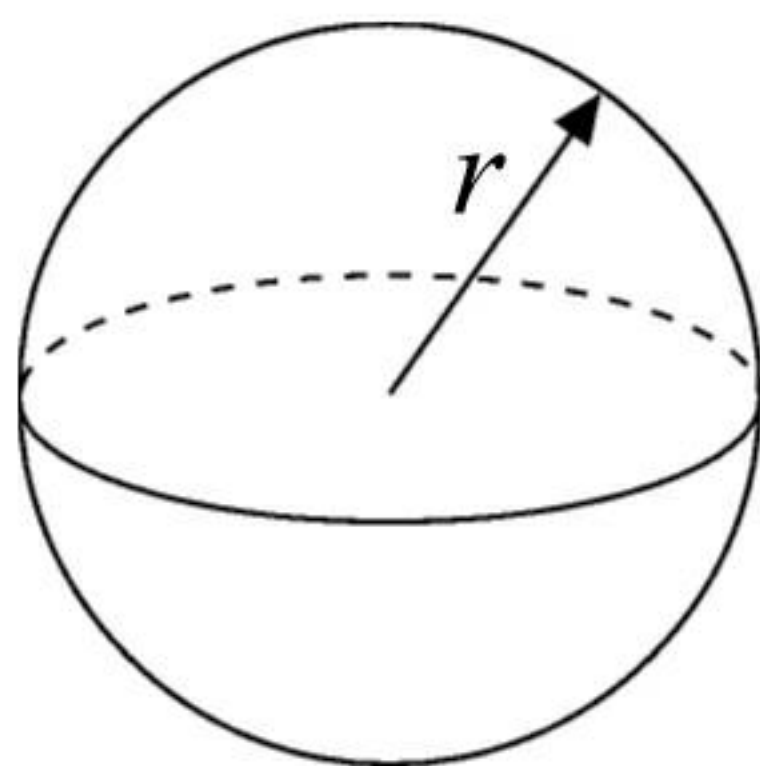

**Volume of cone** =  $\frac{1}{3}\pi r^2 h$

**Curved surface area of cone** =  $\pi r l$

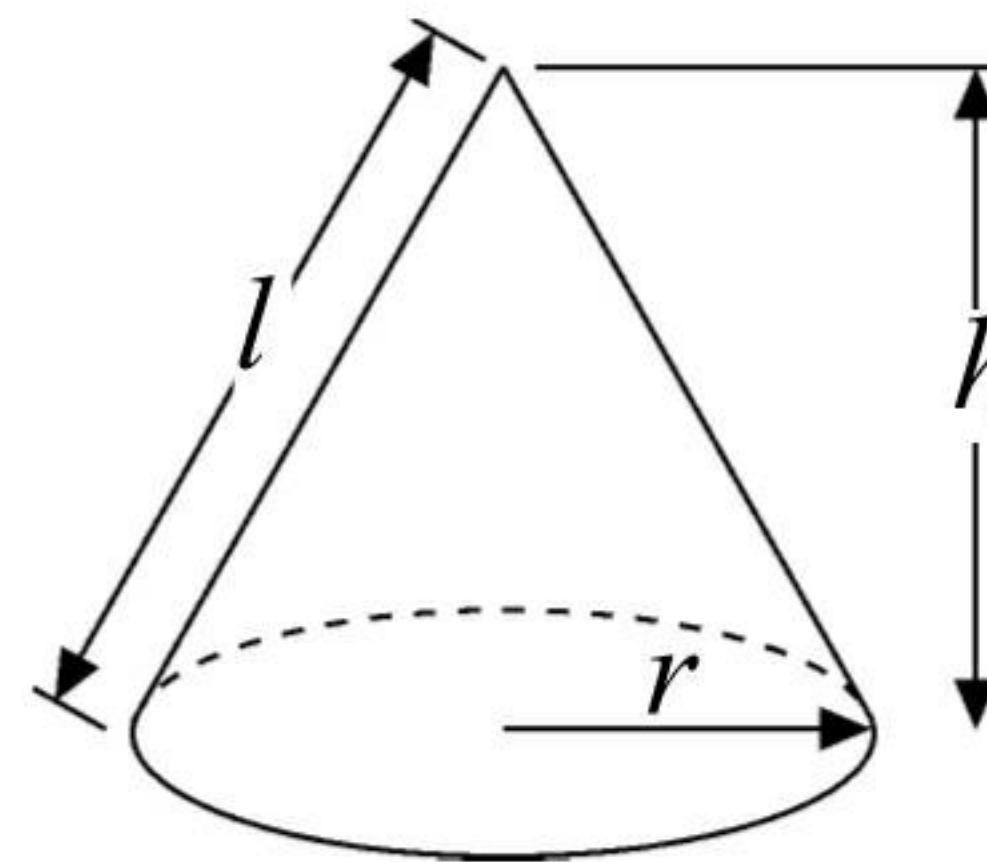

**In any triangle ABC**

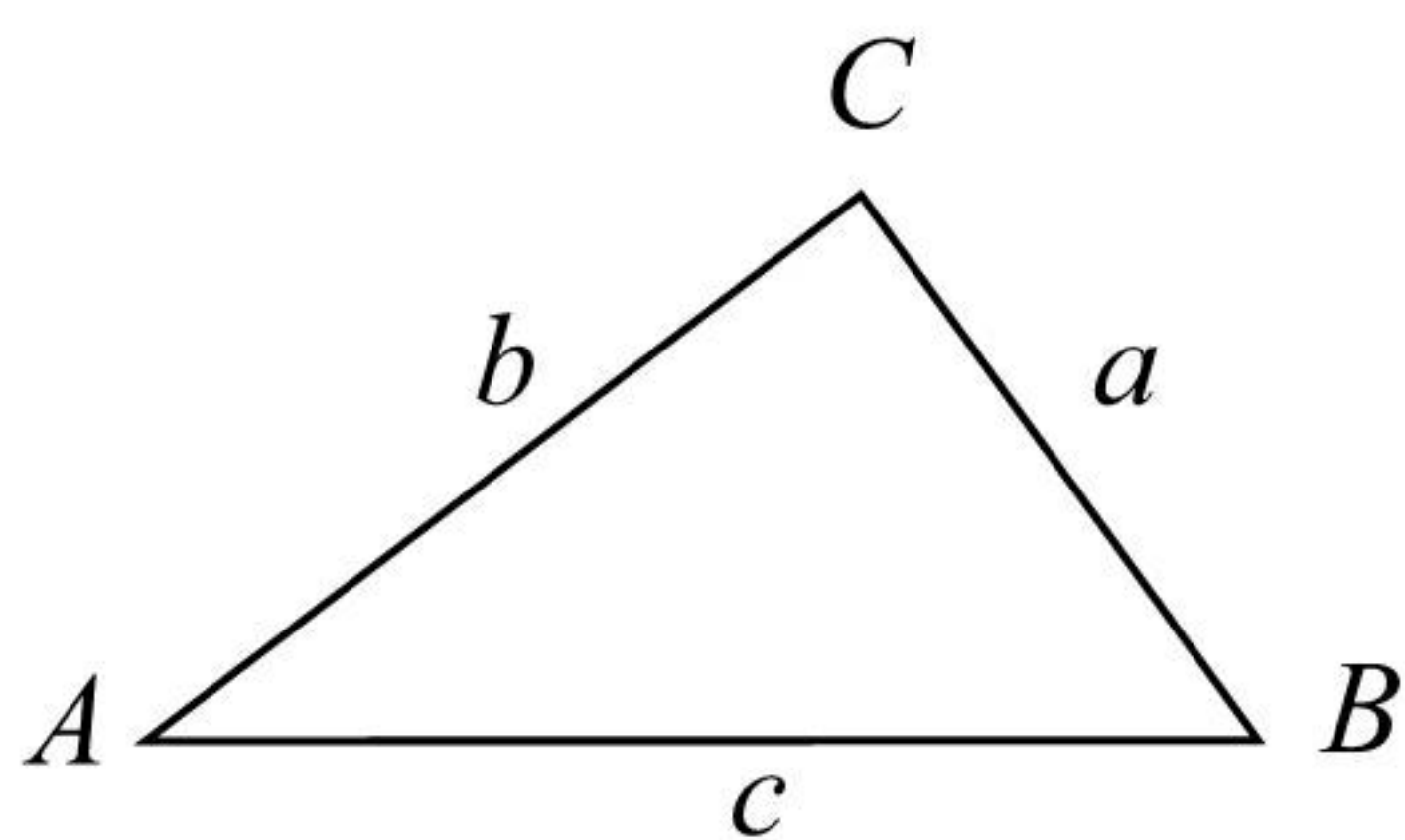

**The Quadratic Equation**

The solutions of  $ax^2 + bx + c = 0$

where  $a \neq 0$ , are given by

$$x = \frac{-b \pm \sqrt{b^2 - 4ac}}{2a}$$

**Sine Rule**  $\frac{a}{\sin A} = \frac{b}{\sin B} = \frac{c}{\sin C}$

**Cosine Rule**  $a^2 = b^2 + c^2 - 2bc \cos A$

**Area of triangle** =  $\frac{1}{2} ab \sin C$



**Answer ALL TWENTY SEVEN questions.**

**Write your answers in the spaces provided.**

**You must write down all stages in your working.**

**You must NOT use a calculator.**

1. Here is a list of ingredients for making 10 Flapjacks.

Ingredients for 10 Flapjacks	
80 g rolled oats	} x1.5
60 g butter	
30 ml golden syrup	
36 g light brown sugar	

Work out the amount of each ingredient needed to make 15 Flapjacks.

.....120..... g rolled oats  
 .....90..... g butter  
 .....45..... ml golden syrup  
 .....54..... g light brown sugar

**(Total 3 marks)**

Q1





2. Harriet reads eight books.

For each book she recorded the number of pages and the time she takes to read it.

The scatter graph shows information about her results.

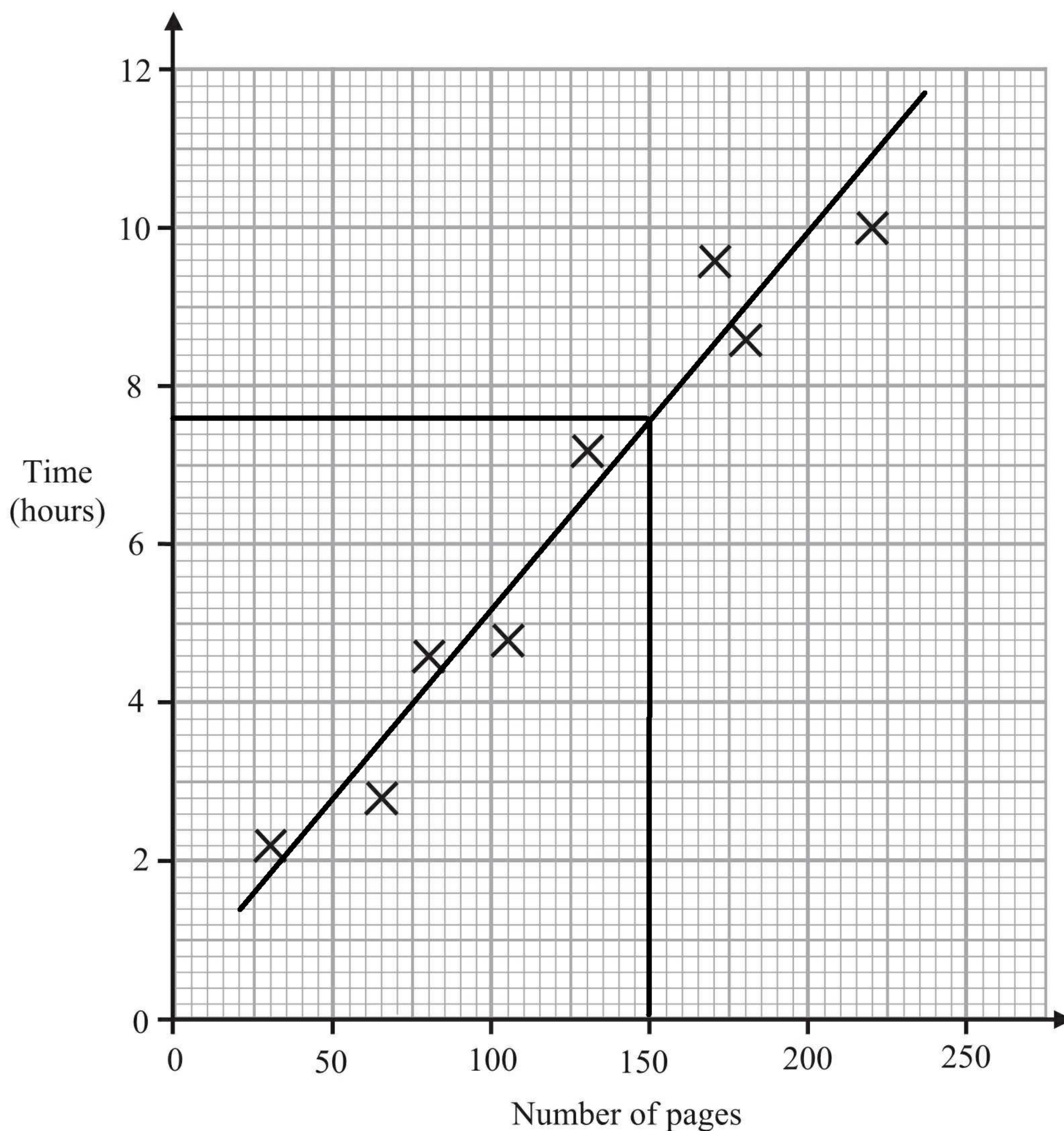

(a) Describe the relationship between the number of pages in a book and the time Harriet takes to read it.

*as the number of pages increase time taken increases* (1)

Harriet reads another book.  
The book has 150 pages.

(b) Estimate the time it takes Harriet to read it.

*7.6* hours (2)

(Total 3 marks)

Q2





3.

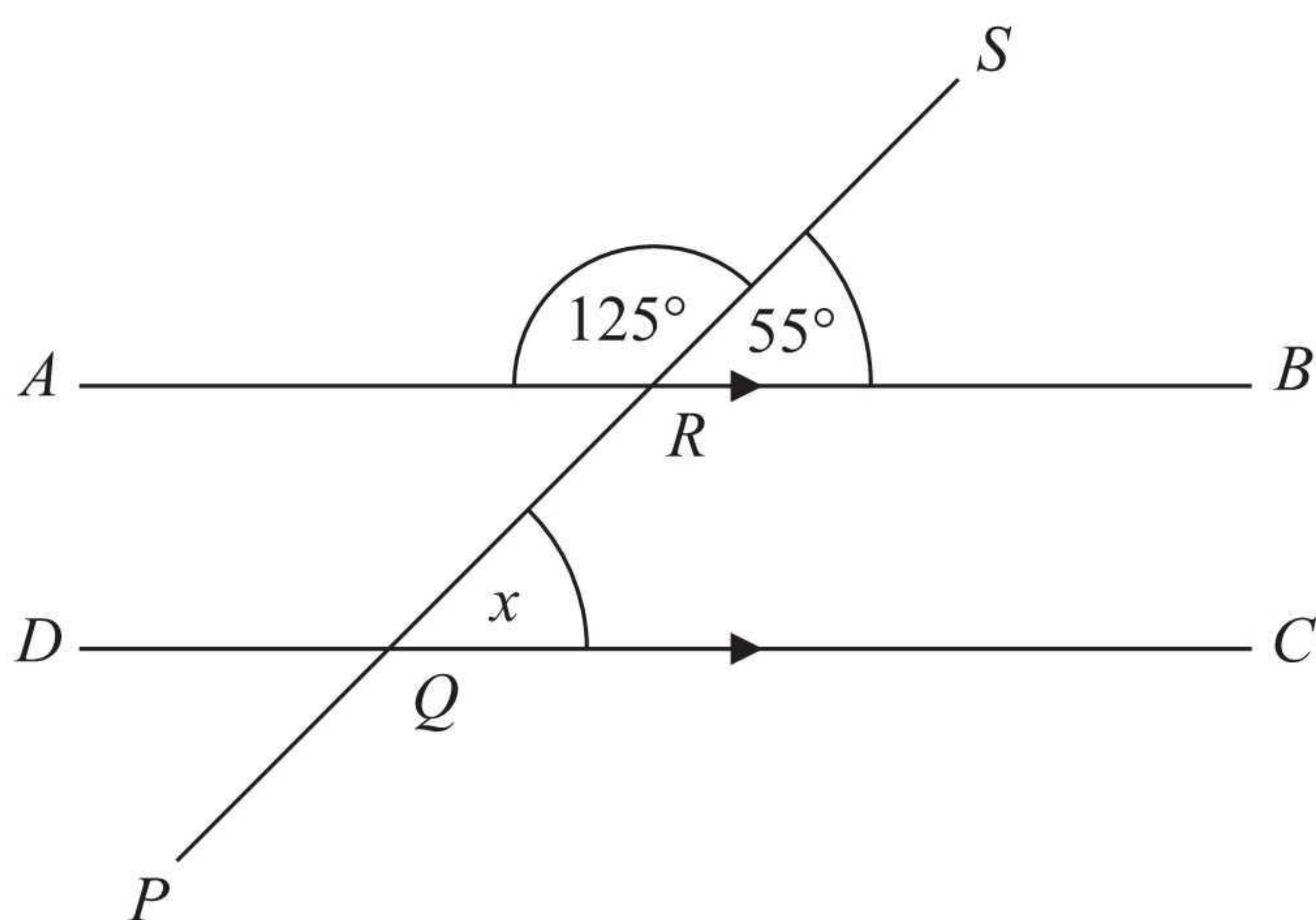

Diagram NOT accurately drawn

$ARB$  is parallel to  $DQC$ .

$PQRS$  is a straight line.

Angle  $SRB = 55^\circ$ .

(i) Find the size of the angle marked  $x$ .

..... 55 .....<sup>o</sup>

(ii) Give a reason for your answer.

..... corresponding angles are equal .....

(Total 2 marks)

Q3

4. Work out an estimate for  $\frac{7.19 \times 19.7}{0.46}$

$$\frac{7 \times 20}{0.5} = \frac{140}{0.5}$$

..... 280 .....

(Total 3 marks)

Q4





5.  $h = 5t^2 + 2$

(a) (i) Work out the value of  $h$  when  $t = -2$

$$5(-2)^2 + 2$$

$$5(4) + 2$$

..... 22

(ii) Work out a value of  $t$  when  $h = 47$

$$47 = 5t^2 + 2$$

$$45 = 5t^2$$

$$9 = t^2$$

.....  $\pm 3$   
(3)

(b)  $-1 \leq n < 4$

$n$  is an integer.

Write down all the possible values of  $n$ .

..... -1, 0, 1, 2, 3  
(2)

(Total 5 marks)

Q5

6. Each exterior angle of a regular polygon is  $30^\circ$ .

Work out the number of sides of the polygon.

$$\frac{360}{30} = 12$$

..... 12

(Total 2 marks)

Q6





7.

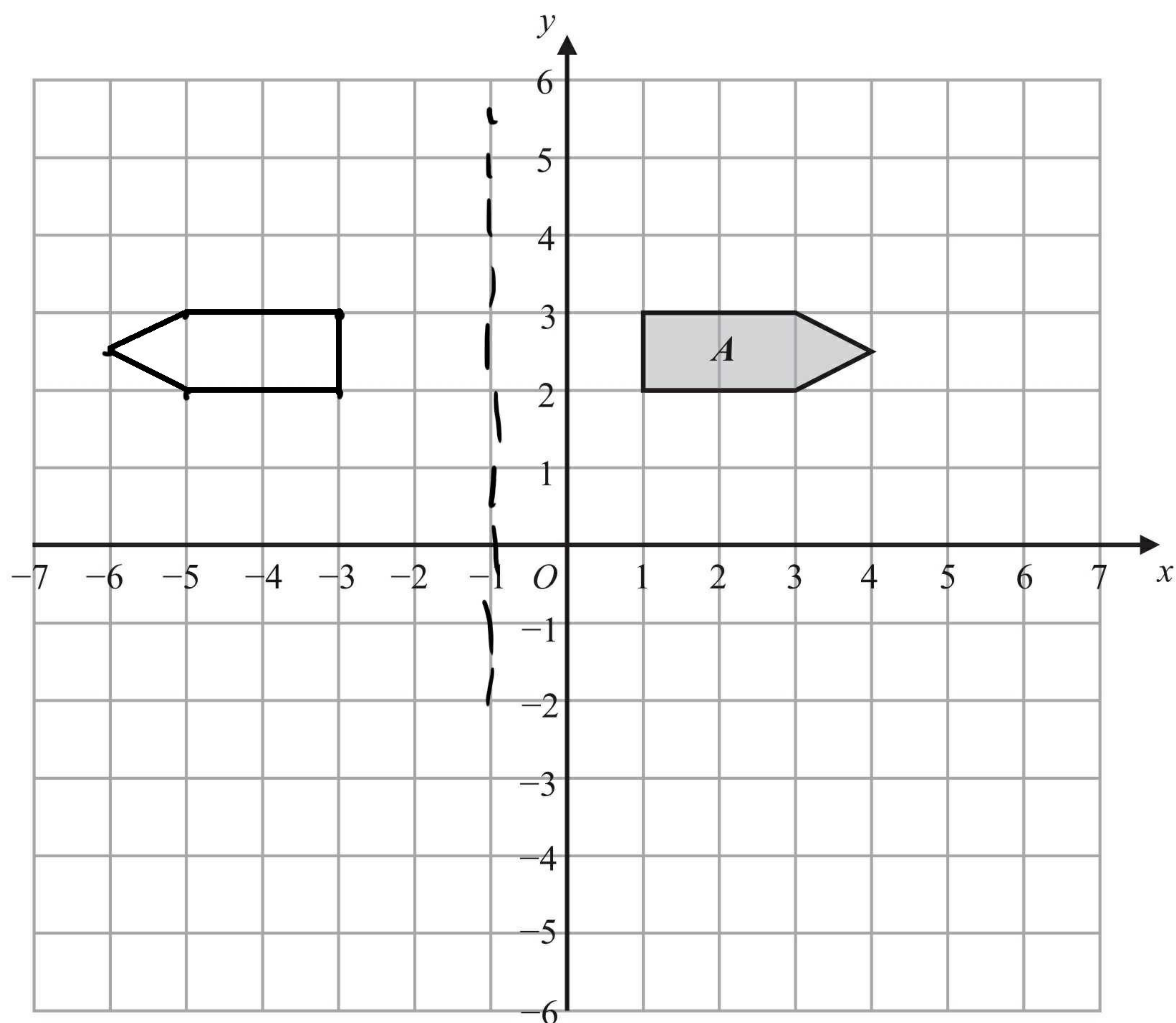

(a) On the grid above, reflect shape *A* in the line  $x = -1$

(2)

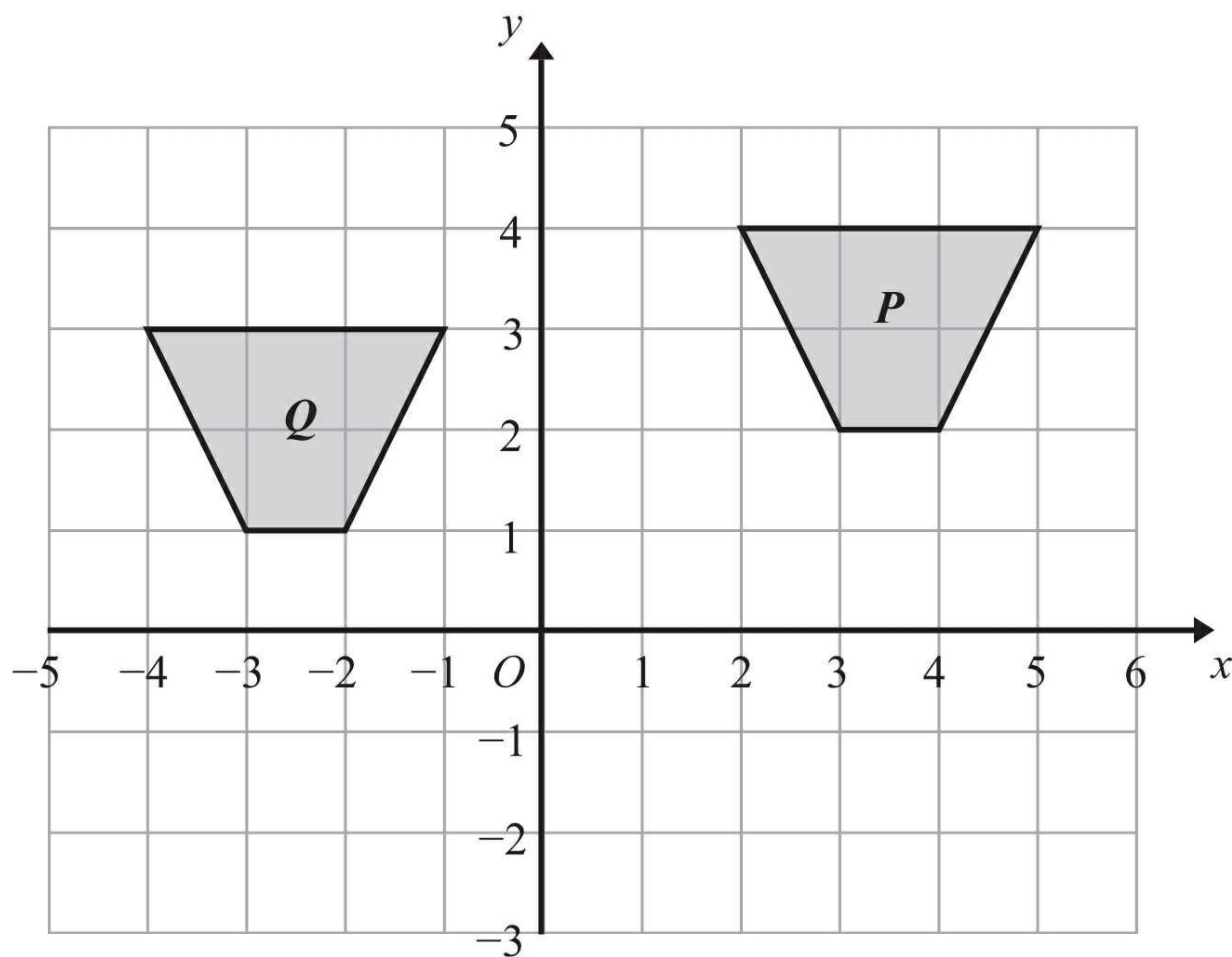

(b) Describe fully the single transformation that will map shape *P* onto shape *Q*.

translation by vector  $\begin{pmatrix} -6 \\ -1 \end{pmatrix}$

(2)

(Total 4 marks)

Q7





8. Sophie wants to find out the amount of time people exercise. She will use a questionnaire.

(a) Design a suitable question for Sophie to use in her questionnaire. You must include some response boxes.

How much time do you spend exercising a week?

0     
  1-2 hours     
  3-4 hours     
  5 hours or more

(2)

Sophie asks the people at her swimming pool to complete her questionnaire. This may **not** be a suitable sample.

(b) Give a reason why.

people at the swimming pool will exercise more.

(1)

(Total 3 marks)

Q8

9. The  $n$ th term of a number sequence is given by  $3n+1$

(a) Work out the first **two** terms of the number sequence.

4, 7

(1)

Here are the first four terms of another number sequence.

1      5      9      13

(b) Find, in terms of  $n$ , an expression for the  $n$ th term of this number sequence.

$4n-3$

(2)

(Total 3 marks)

Q9





10.

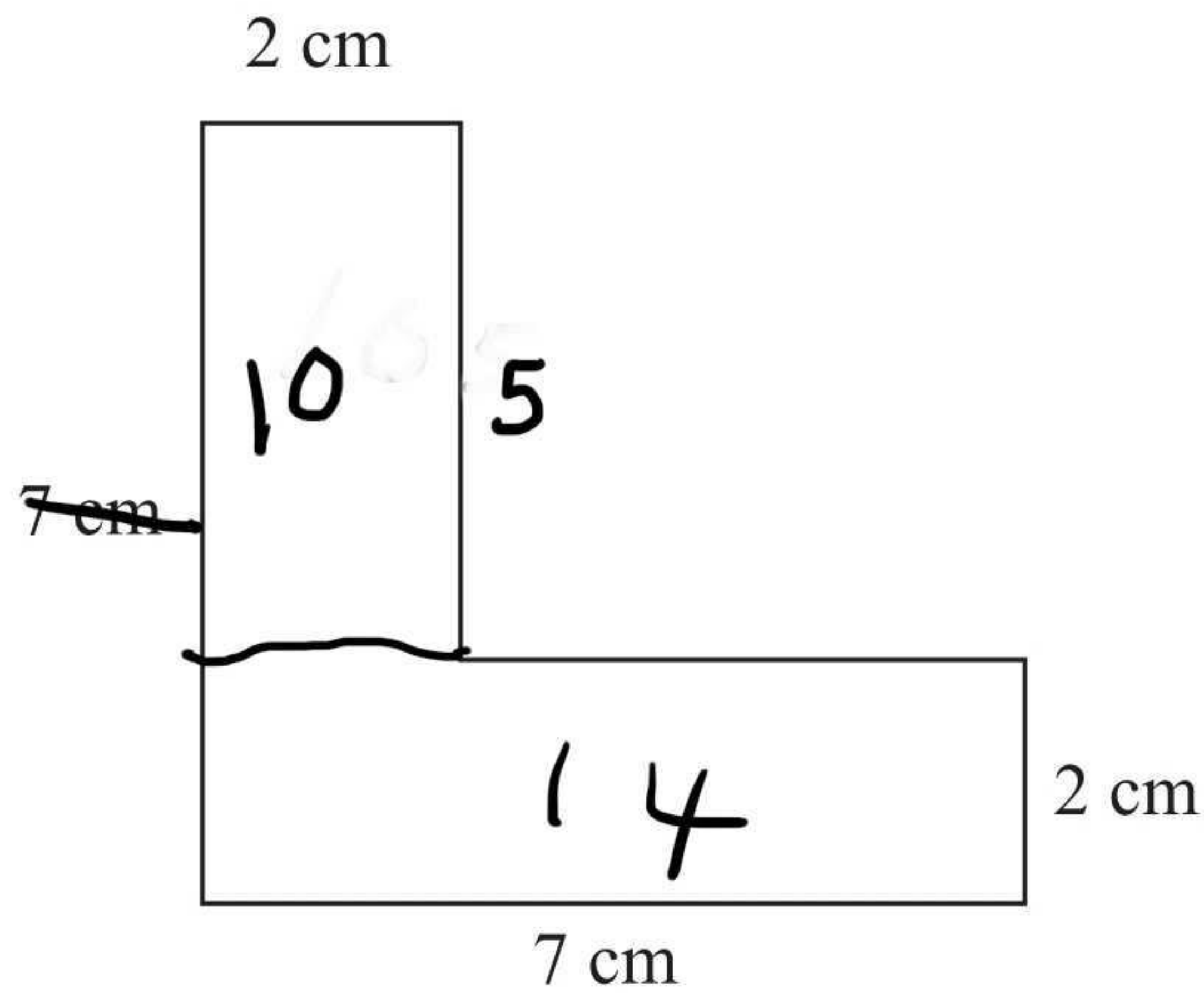

Diagram NOT accurately drawn

The diagram shows the cross-section of a solid prism.  
The length of the prism is 2 m.

*2000cm*

The prism is made from metal.  
The density of the metal is 8 grams per cm<sup>3</sup>.

Work out the mass of the prism.

$$\text{density} = \frac{\text{mass}}{\text{volume}}$$

$$\text{vol} = 24 \times 200 \quad \left( \text{vol of prism} = \text{area of cross section} \times \text{length} \right)$$

$$= 4800 \text{ cm}^3$$

$$8 = \frac{\text{mass}}{480}$$

$$\begin{array}{r|l} & 400 \\ \hline 8 & 3200 \end{array} \quad \begin{array}{r} 80 \\ \hline 640 \end{array}$$

$$\begin{array}{r} 3200 \\ 640 \\ \hline 3840 \end{array}$$

.....*3840g*.....  
(Total 5 marks)

Q10





11. Peter, Tarish and Ben share £54

Tarish gets three times as much money as Peter.  
Ben gets twice as much money as Tarish.

How much money does Ben get?

$$T : P : B$$

$$3 : 1 : 6$$

10 parts

$$£54 \div 10 = £5.40$$

Ben gets  $6 \times 5.40$

$$\begin{array}{r|l} 500 & 40 \\ \hline 6 & 3000 \end{array} \begin{array}{l} \\ 240 \end{array}$$

£ 32.40

(Total 3 marks)

Q11

12. (a) Simplify

(i)  $w^6 \times w^4$

.....  $w^{10}$  .....

(ii)  $h^8 \div h^3$

.....  $h^5$  .....

(2)

(b) Simplify completely  $\frac{12xy^3}{3x^2y^3}$

.....  $4x^{-1}$  .....

(2)

(Total 4 marks)

Q12





13. The table shows some information about the weights, in kg, of 100 boxes.

Weight of box ( $w$ kg)	Frequency
$0 < w \leq 4$	10
$4 < w \leq 8$	17
$8 < w \leq 12$	28
$12 < w \leq 16$	25
$16 < w \leq 20$	20

Draw a frequency polygon to show this information.

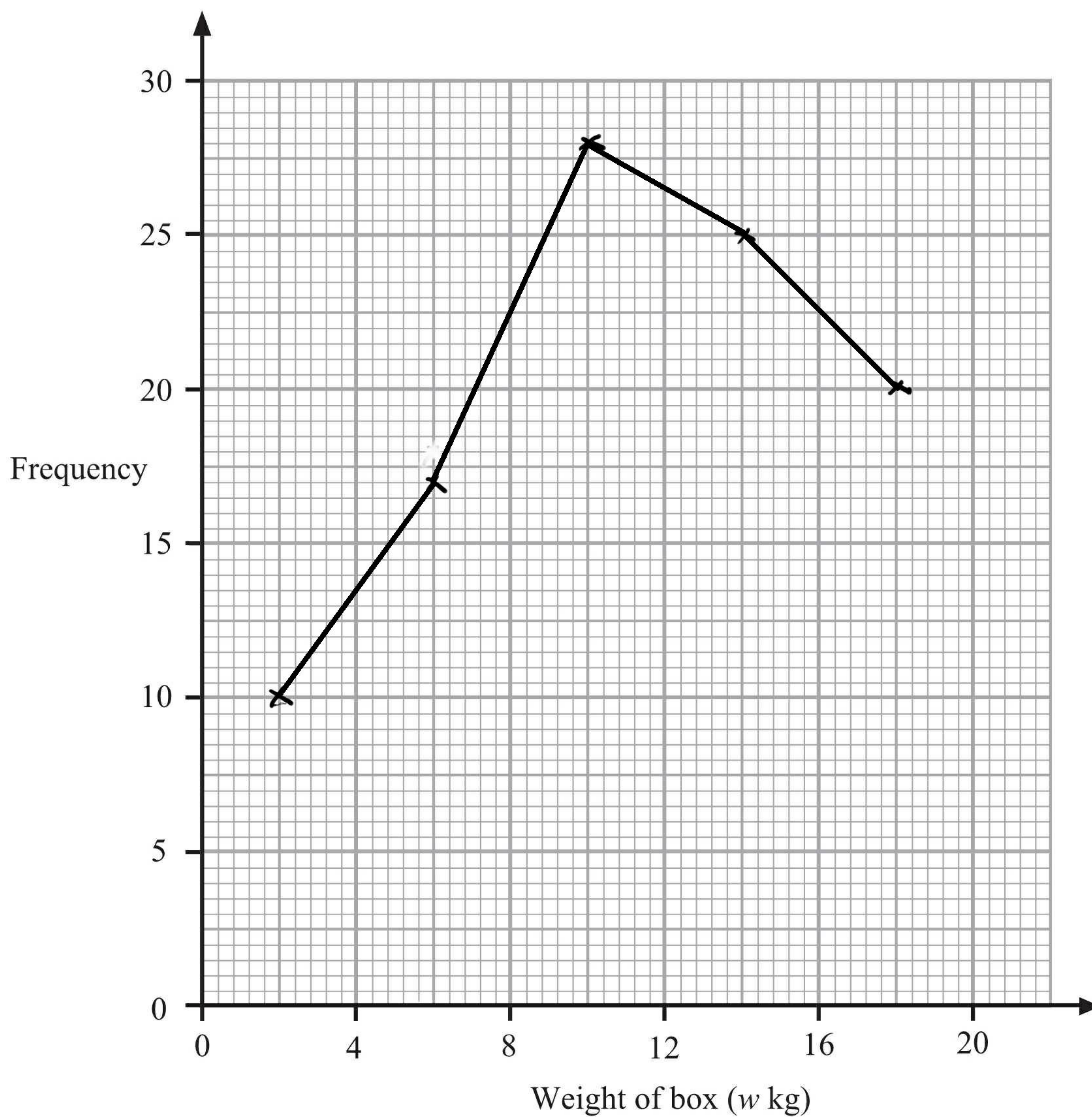

Q13

(Total 2 marks)





14. Use ruler and compasses to **construct** an angle of  $30^\circ$  at  $P$ .  
You **must** show all your construction lines.

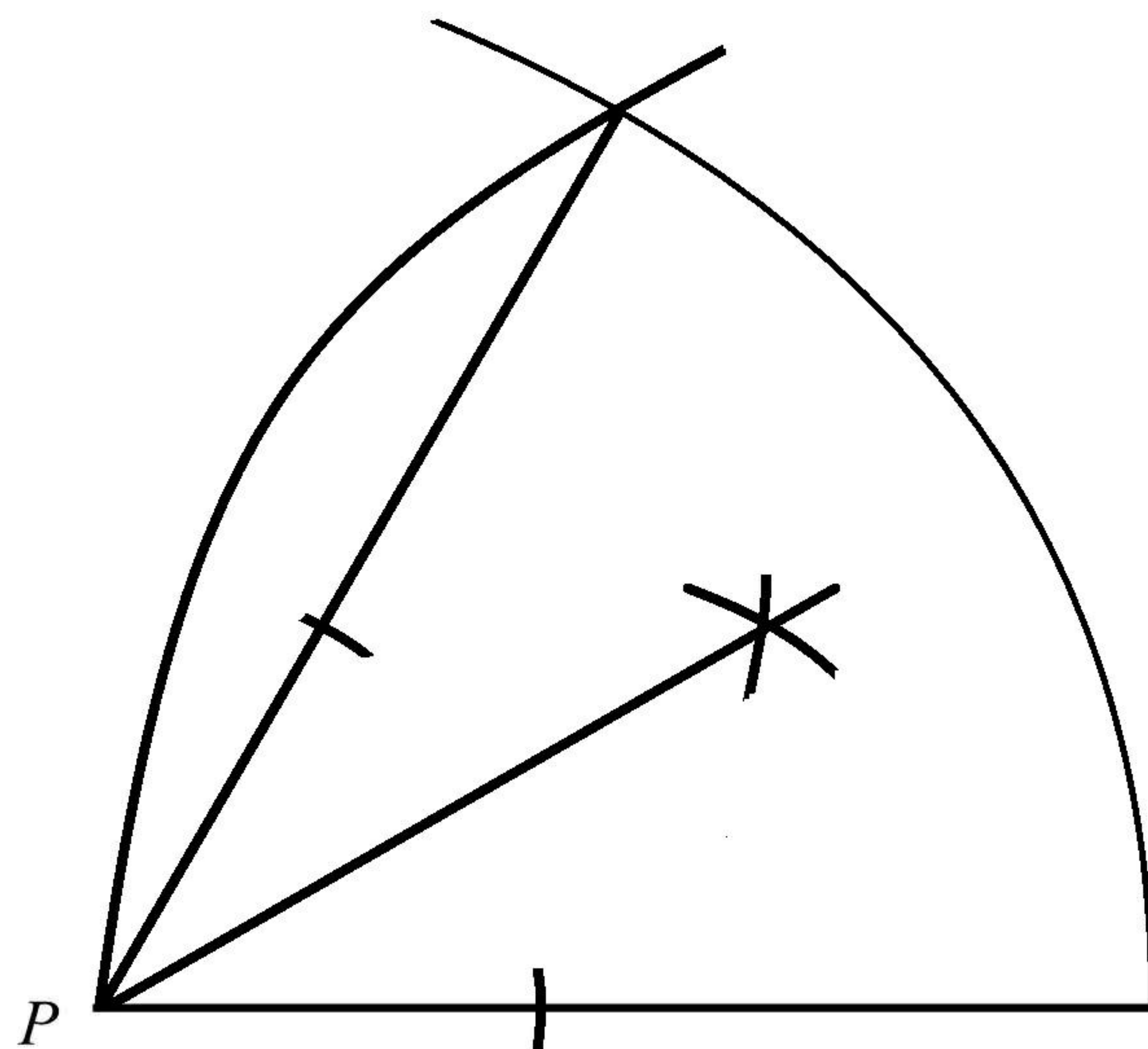

(Total 3 marks)

Q14

15. (a) Expand  $x(x + 2)$

$$\underline{x^2 + 2x}$$

(2)

(b) Expand and simplify  $(x + 3)(x - 4)$

$$x^2 - 4x + 3x - 12$$

$$\underline{x^2 - x - 12}$$

(2)

(c) Factorise completely  $2y^2 - 4y$

$$\underline{2y(y - 2)}$$

(2)

(d) Factorise  $x^2 - 9$

$$\underline{(x + 3)(x - 3)}$$

(1)

(Total 7 marks)

Q15





16. (a) Work out  $\frac{2}{3} \div \frac{5}{6}$

Give your fraction in its simplest form.

$$\frac{2}{3} \times \frac{6}{5} = \frac{12}{15} = \frac{4}{5}$$

$$\frac{4}{5}$$

(3)

(b) Work out  $2\frac{1}{3} - 1\frac{2}{5}$

$$\frac{7}{3} - \frac{7}{5}$$

$$\frac{35}{15} - \frac{21}{15} = \frac{14}{15}$$

$$\frac{14}{15}$$

(3)

Q16

(Total 6 marks)





17.

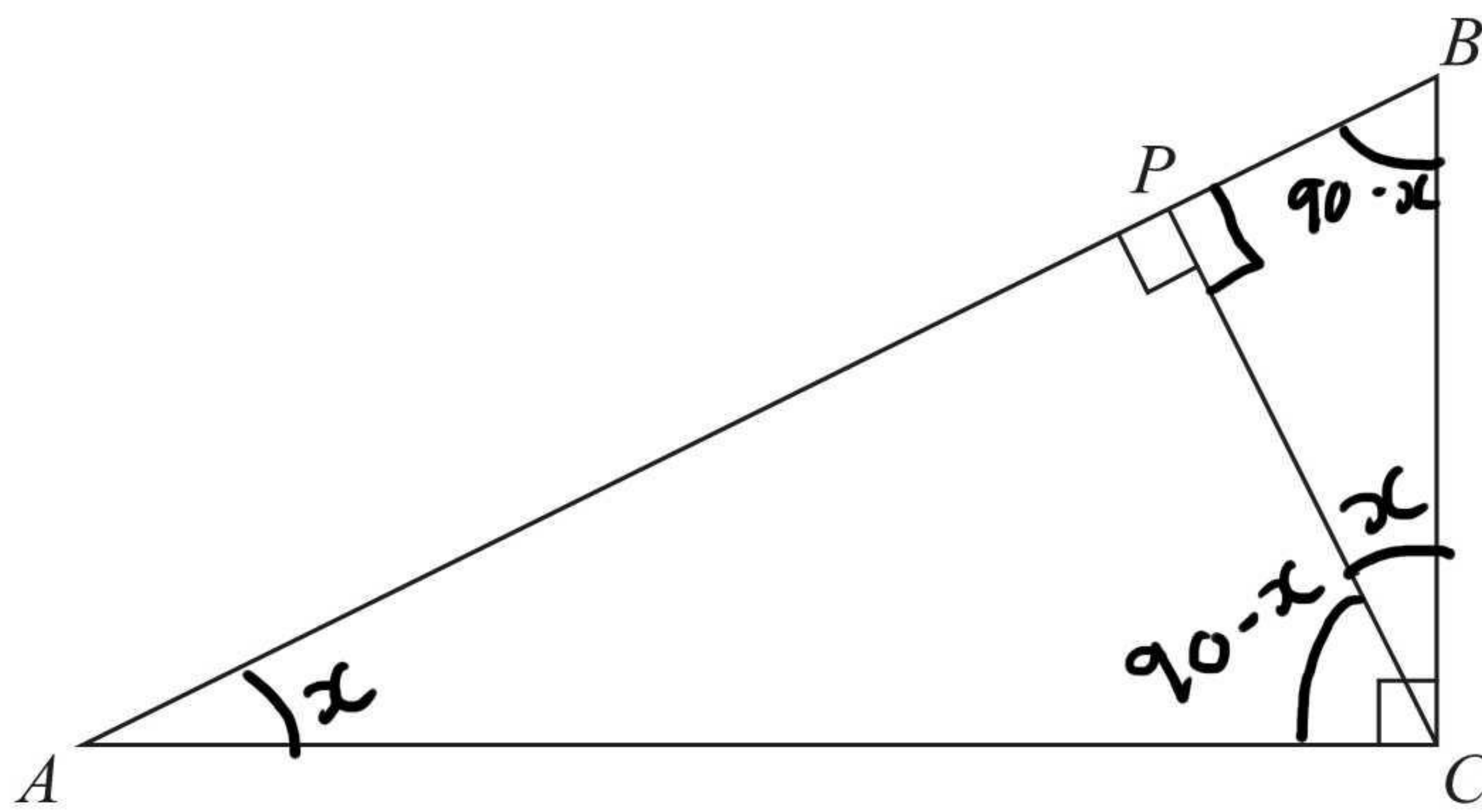

Diagram NOT accurately drawn

In the diagram,

$ABC$  is a triangle,  
 angle  $ACB = 90^\circ$ ,  
 $P$  lies on the line  $AB$ ,  
 $CP$  is perpendicular to  $AB$ .

Prove that the angles of triangle  $APC$  are the same as the angles of triangle  $CPB$ .

$$\hat{BPC} = \hat{APC}$$

Angles on straight line  
 add up to  $180^\circ$

if angle  $BCP = x^\circ$

$$\hat{CBP} \text{ and } \hat{CAP} = (90 - x)^\circ$$

$$\therefore \hat{CAP} = x$$

Angles in triangle add up  
 to  $180^\circ$

Q17

(Total 3 marks)





**BLANK PAGE**

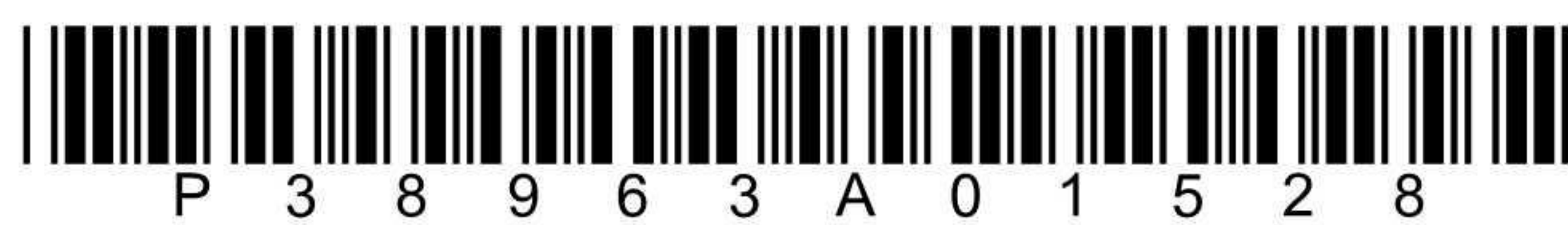



18. The table shows information about the time,  $m$  minutes, it takes to show each of 120 films.

Time ( $m$ minutes)	Frequency
$70 < m \leq 80$	4
$80 < m \leq 90$	12
$90 < m \leq 100$	34
$100 < m \leq 110$	32
$110 < m \leq 120$	26
$120 < m \leq 130$	12

(a) Write down the modal class interval.

$90 < m \leq 100$   
(1)

(b) Complete the cumulative frequency table.

Time ( $m$ minutes)	Cumulative frequency
$70 < m \leq 80$	4
$70 < m \leq 90$	16
$70 < m \leq 100$	50
$70 < m \leq 110$	82
$70 < m \leq 120$	108
$70 < m \leq 130$	120

(1)





(c) On the grid, draw a cumulative frequency graph for your cumulative frequency table.

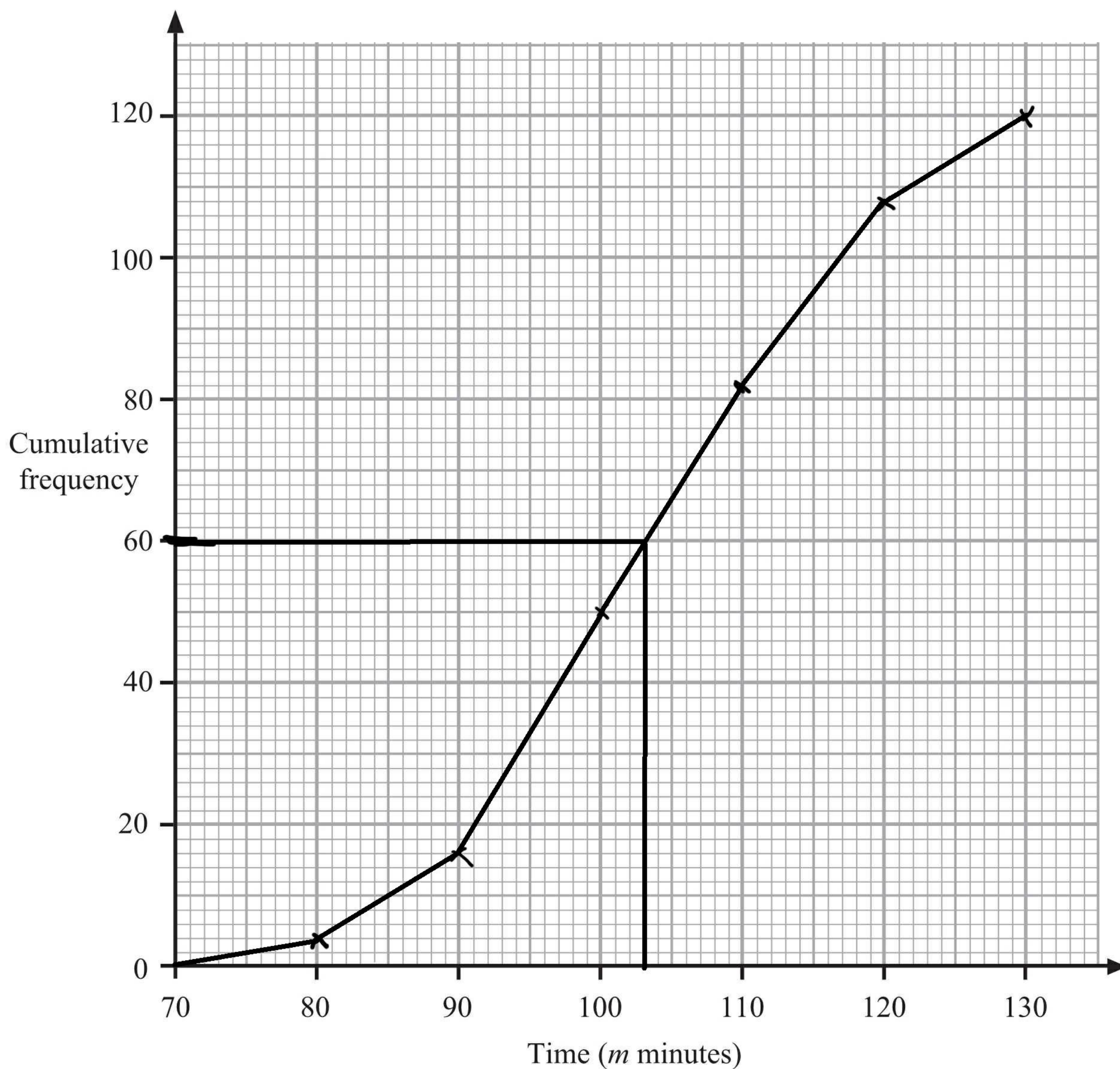

(2)

(d) Use your graph to find an estimate for the median.

.....103..... minutes  
(1)

Q18

(Total 5 marks)

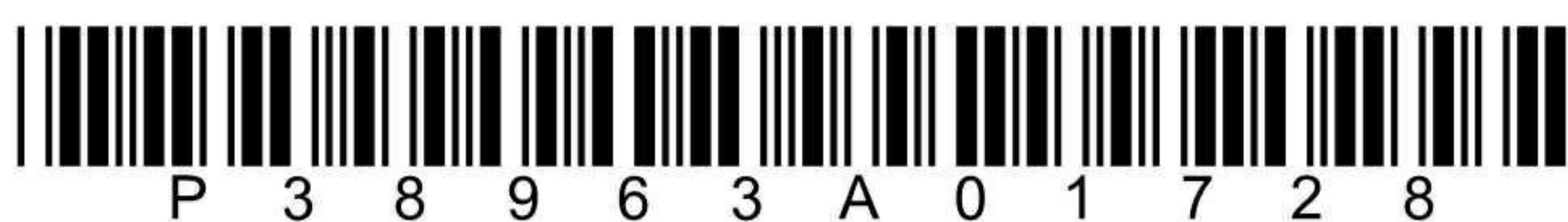



19. Solve the simultaneous equations

$$\begin{aligned} 4x + y &= 10 & \times 3 \\ 2x - 3y &= 19 \end{aligned}$$

$$\begin{aligned} 12x + 3y &= 30 \\ + & \\ 2x - 3y &= 19 \end{aligned}$$

$$14x = 49$$

$$2x = 7$$

$$x = 3.5$$

$$4(3.5) + y = 10$$

$$14 + y = 10$$

$$y = -4$$

$$x = \dots 3.5 \dots$$

$$y = \dots -4 \dots$$

(Total 3 marks)

Q19





20. The box plots show information about the points scored by some students in a spelling competition.

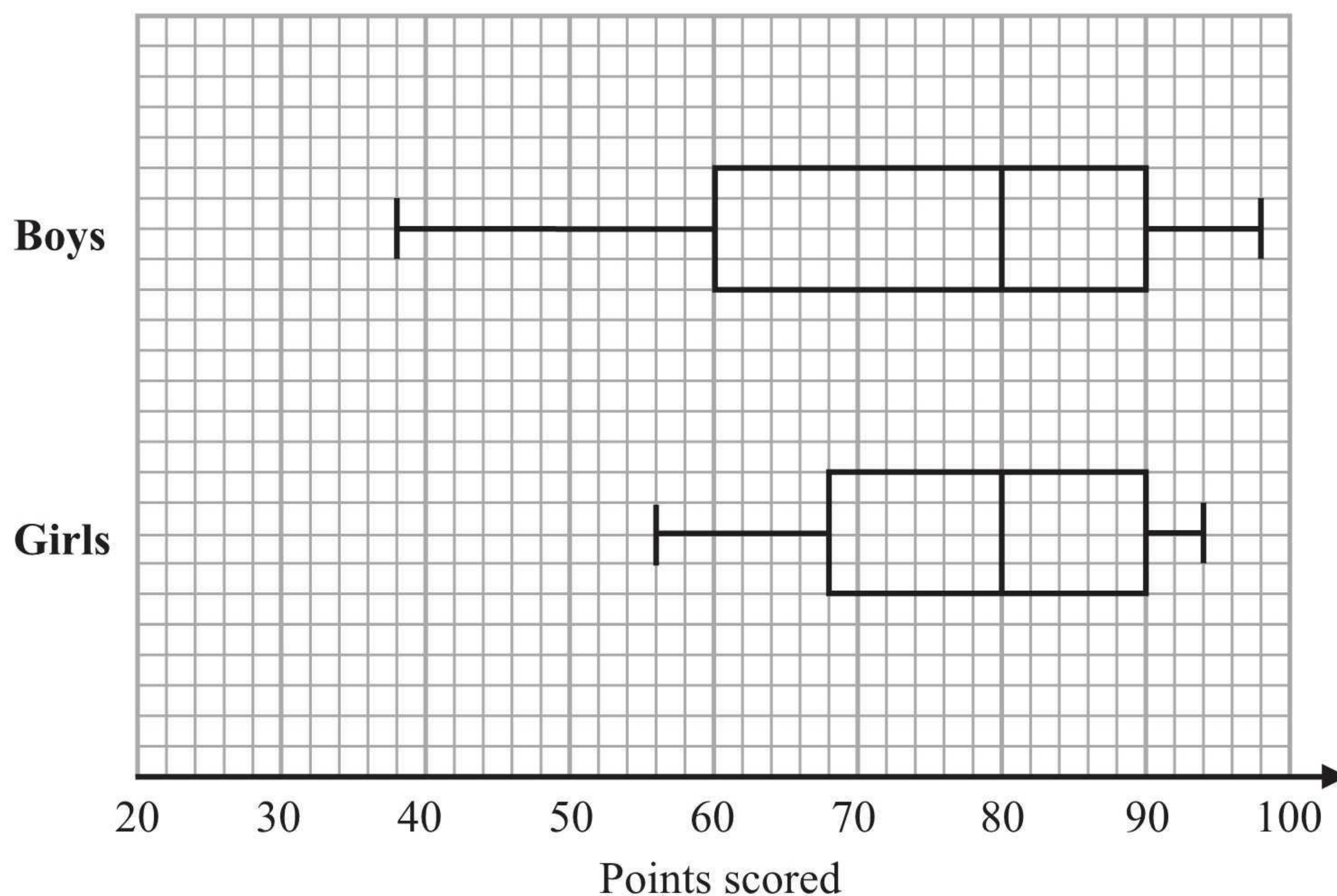

Compare the distributions of the boys' scores and the girls' scores.

the median score was the same  
 the boys had a bigger inter quartile  
 range

(Total 2 marks)

Q20





21.

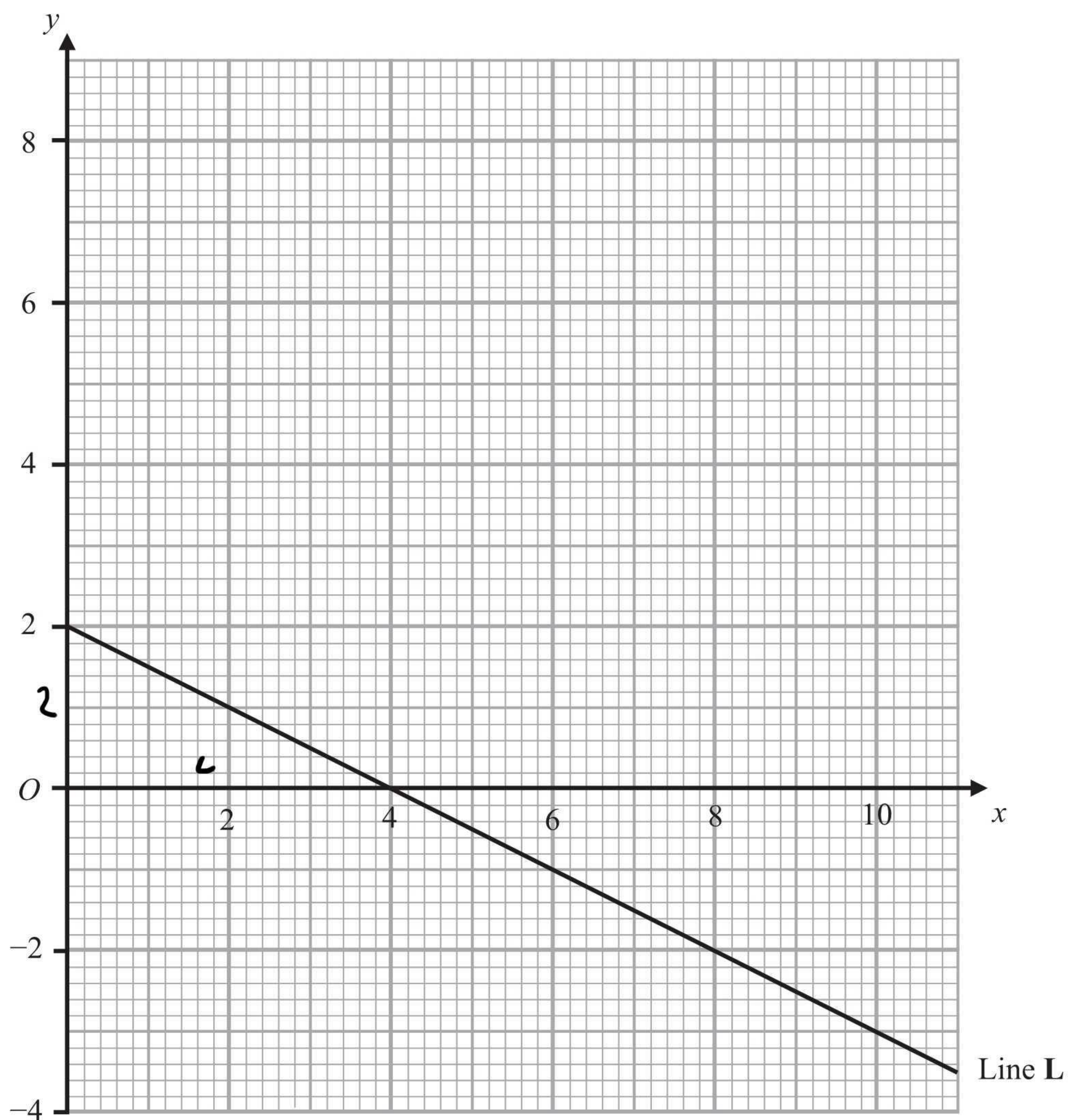

Line L is drawn on the grid.

(a) Work out the gradient of Line L.

$$\frac{-2}{4} \qquad \dots\dots\dots -\frac{1}{2} \qquad (2)$$

Another line, Line M, is parallel to Line L and passes through the point (6, 2).

$x \ y$

(b) Find an equation for Line M.

$$y = -\frac{1}{2}x + c$$

$$2 = -\frac{1}{2}(6) + c$$

$$2 = -3 + c$$

$$c = 5$$

$$\dots\dots\dots y = -\frac{1}{2}x + 5 \qquad (2)$$

(Total 4 marks)

Q21





22. (a) Find the value of  $27^{-\frac{2}{3}}$

$$3^{-2}$$

$$\frac{1}{9}$$

(2)

(b) Given that

$$\frac{8 - \sqrt{18}}{\sqrt{2}} = a + b\sqrt{2}, \text{ where } a \text{ and } b \text{ are integers,}$$

find the value of  $a$  and the value of  $b$ .

$$\frac{(8 - \sqrt{18}) \times \sqrt{2}}{\sqrt{2} \times \sqrt{2}}$$

$$\frac{8\sqrt{2} - \sqrt{36}}{2}$$

$$\frac{8\sqrt{2} - 6}{2}$$

$$4\sqrt{2} - 3$$

$$-3 + 4\sqrt{2}$$

$$a = \dots -3 \dots$$

$$b = \dots 4 \dots$$

(3)

(Total 5 marks)

Q22





23. Make  $k$  the subject of the formula  $t = \frac{k}{k-2}$

$$t(k-2) = k$$

$$tk - 2t = k$$

$$tk = k + 2t$$

$$tk - k = 2t$$

$$k(t-1) = 2t$$

$$k = \frac{2t}{t-1}$$

$$k = \frac{2t}{t-1}$$

Q23

(Total 4 marks)





24. The incomplete table and histogram give some information about the heights (in cm) of some sunflowers.

Height ( $h$ cm)	Frequency
$100 < h \leq 130$	30
$130 < h \leq 150$	84
$150 < h \leq 160$	60
$160 < h \leq 180$	40
$180 < h \leq 210$	18

$F \cdot d$   
 1  
 4.2  
 6  
 2  
 0.6

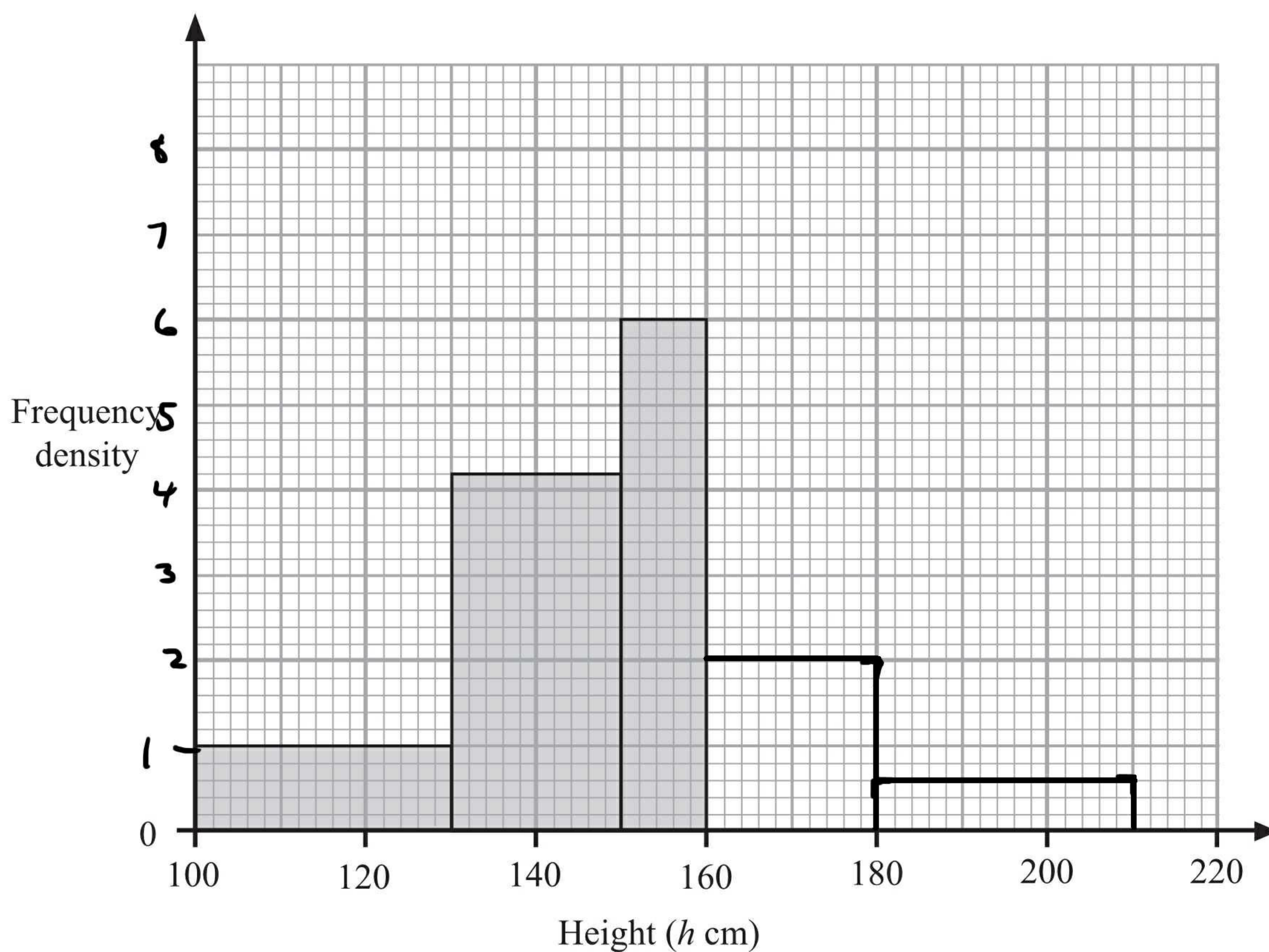

(a) Use the histogram to complete the table.

(2)

(b) Use the table to complete the histogram.

(2)

(Total 4 marks)

Q24

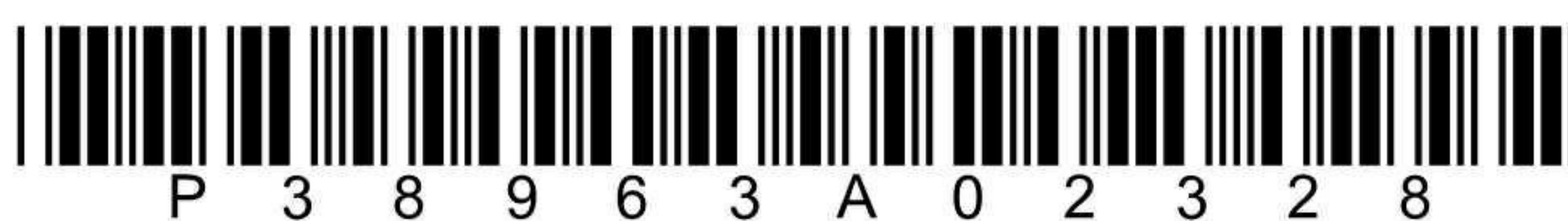

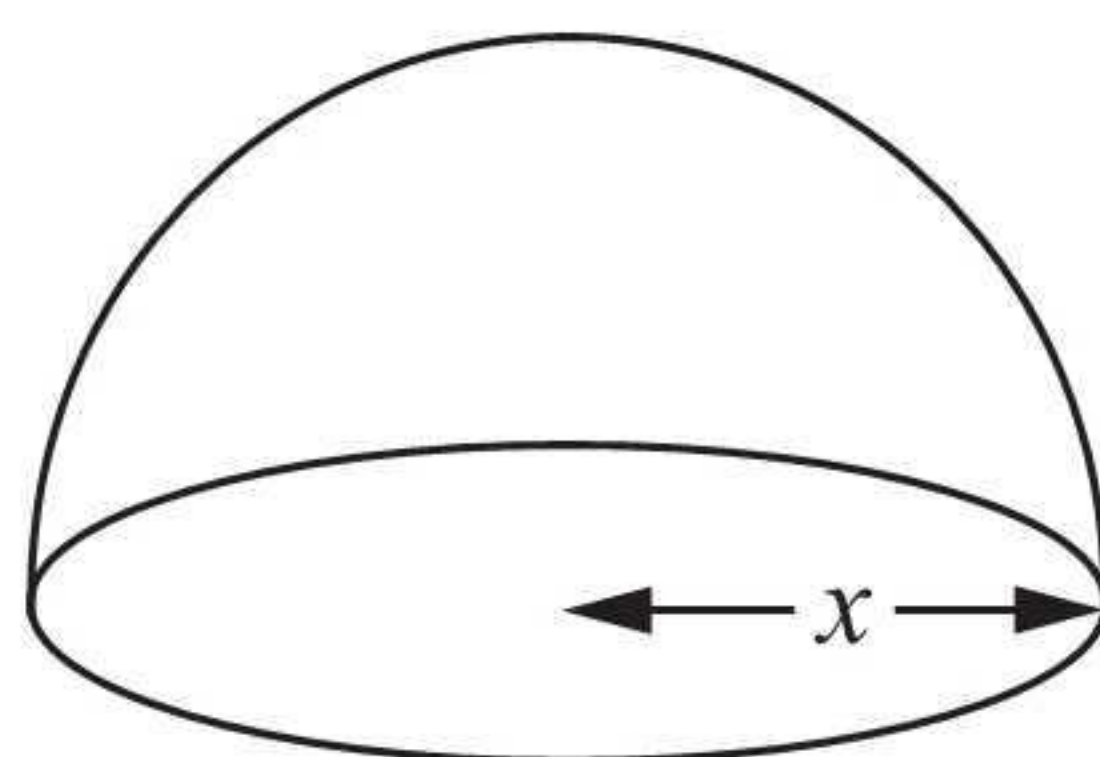
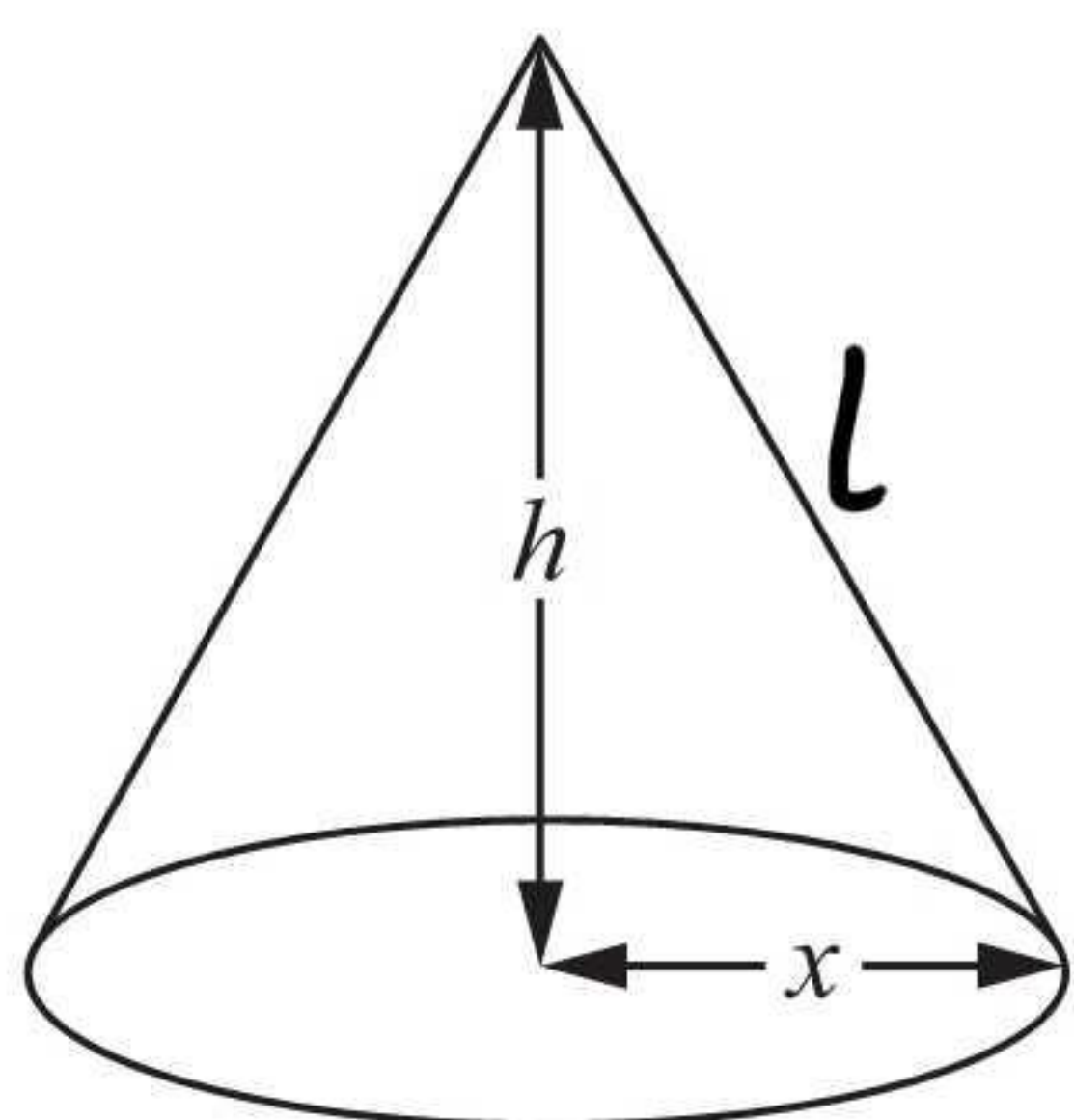

25.

Leave  
blankDiagram NOT  
accurately drawn

The diagram shows a solid cone and a solid hemisphere.

The cone has a base of radius  $x$  cm and a height of  $h$  cm.

The hemisphere has a base of radius  $x$  cm.

The surface area of the cone is equal to the surface area of the hemisphere.

Find an expression for  $h$  in terms of  $x$ .

surface area cone = surface area hemisphere

$$\pi r l + \pi r^2 = \frac{4\pi r^2}{2} + \pi r^2$$

$$\pi x l + \pi x^2 = 2\pi x^2 + \pi x^2$$

$$x(l + x^2) = 3x^2$$

$$l + x = 3x$$

$$l = 2x$$

$$h^2 + x^2 = l^2$$

$$h^2 = l^2 - x^2$$

$$h^2 = (2x)^2 - x^2$$

$$h^2 = 4x^2 - x^2$$

$$h^2 = 3x^2$$

$$h = \sqrt{3x^2}$$

$$h = \sqrt{3} x$$

Q25

(Total 4 marks)



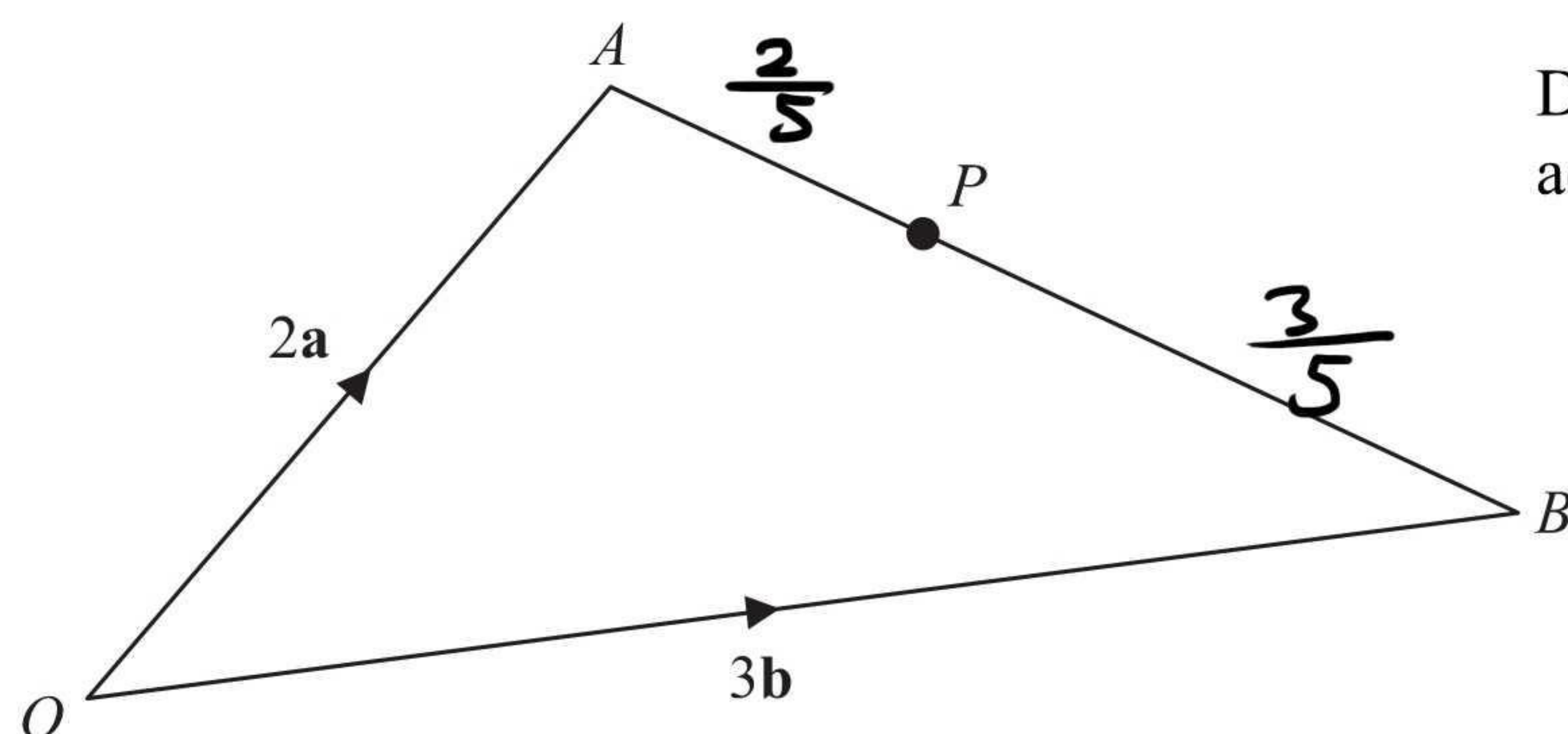

26.

Leave  
blankDiagram **NOT**  
accurately drawn $OAB$  is a triangle.

$$\vec{OA} = 2\mathbf{a}$$

$$\vec{OB} = 3\mathbf{b}$$

(a) Find  $\vec{AB}$  in terms of  $\mathbf{a}$  and  $\mathbf{b}$ .

$$\vec{AB} = \underline{\underline{-2\mathbf{a} + 3\mathbf{b}}}$$

(1)

 $P$  is the point on  $AB$  such that  $AP : PB = 2 : 3$ (b) Show that  $\vec{OP}$  is parallel to the vector  $\mathbf{a} + \mathbf{b}$ .

$$\begin{aligned} \vec{OP} &= 2\mathbf{a} + \frac{2}{5}(-2\mathbf{a} + 3\mathbf{b}) \\ &= 2\mathbf{a} - \frac{4}{5}\mathbf{a} + \frac{6}{5}\mathbf{b} \\ &= \frac{6}{5}\mathbf{a} + \frac{6}{5}\mathbf{b} \\ &= \frac{6}{5}(\mathbf{a} + \mathbf{b}) \end{aligned}$$

$\vec{OP}$  is  $\therefore$  parallel to  $\mathbf{a} + \mathbf{b}$

(3)

(Total 4 marks)

Q26





27. Solve the equation

$$\frac{x}{2} - \frac{2}{x+1} = 1$$

Leave  
blank

$$\frac{x(x+1)}{2(x+1)} - \frac{4}{2(x+1)} = 1$$

$$\frac{x^2 + x - 4}{2(x+1)} = 1$$

$$x^2 + x - 4 = 2x + 2$$

$$x^2 - x - 6 = 0$$

$$(x+2)(x-3) = 0$$

$$x = -2 \text{ or } x = 3$$

$$\underline{x = -2 \text{ or } x = 3}$$

(Total 4 marks)

Q27

TOTAL FOR PAPER: 100 MARKS

END

